

# Rolls

**S2-I 600GEL**  
2V 1870 AH @C100

**TUBULAR POSITIVE - OPzV - VALVE REGULATED GEL BATTERY**



**Rolls**  
BATTERY ENGINEERING  
BY SURRETTE BATTERY COMPANY

SAI GLOBAL  
ISO 9001  
Quality

**CONSTANT CURRENT DISCHARGE**

CUT OFF VOLTAGE V/CELL	30M	1HR	2HR	3HR	5HR	6HR	8HR	10HR	20HR
1.6V	1388	948	575	413	266	239	182	158	83

**SPECIFICATIONS**

Nominal Voltage		2 Volt
Rated Capacity (20 hour rate)		1600 AH
Dimensions	Total Height (including terminals)	831mm / 32.72"
	Length	275mm / 10.83"
	Width	210mm / 8.27"
	Weight	242.51 lbs / 110.0 Kg



**CYCLE LIFE**

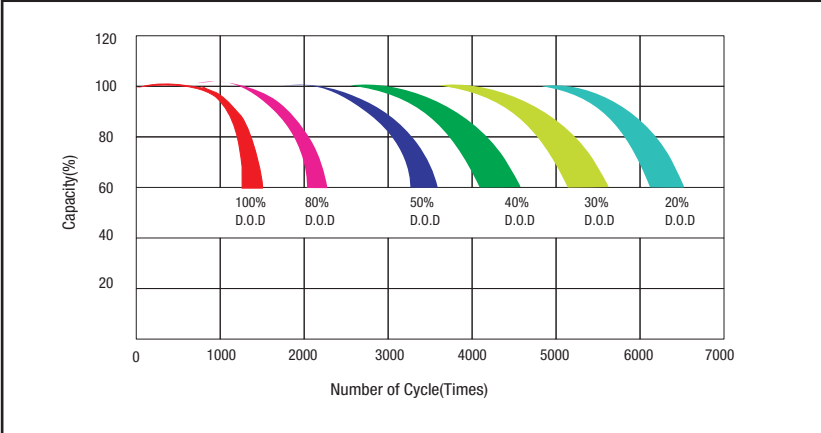

**CHARACTERISTICS**

Capacity 77°F (25°C)	100 Hour Rate	1870 AH
	20 Hour Rate	1600 AH
	10 Hour Rate	1500 AH
Internal Resistance	Full charged Battery 77°F (25°C)	0.23mΩ
Capacity Affected by Temperature (20hr rate)	104°F (40°C)	105%
	77°F (25°C)	100%
	32°F (0°C)	89%
	5°F (-15°C)	79%
Self-Discharge	Less than 2% per month at 77°F (25°C)	
Max Discharge 77°F (25°C)	4500A (5s)	
Terminal	Standard	Thread insert & Bolt (F10-M8)
Float Charging Voltage Range	2.25 to 2.3 VDC/unit Average at 25°C	
Max Charge Current	300 Amps	

**SIZE & DETAILED ILLUSTRATION**

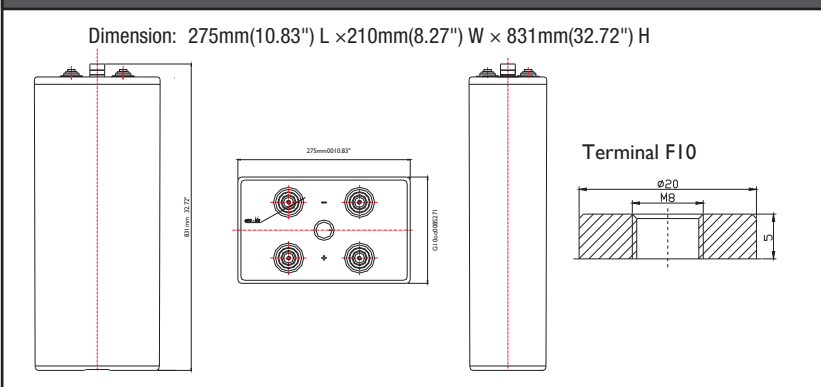

**TEMP EFFECTS ON LIFE AT FLOAT CHARGE**

